

IJBW-134

IP Camera Wall Mount Junction Box

Infinique's IJBW-134 Wall Mount Junction Box provides an easy and effective way to mount video surveillance cameras in the wall. The junction box is waterproof and protects the Ethernet connectors from moisture and dust. It safely conceals all the cabling giving the finished installation an aesthetic look. These junction boxes are suitable for installation both indoor and outdoor environment.

Product Features

- Indoor and Outdoor Wall Mount Junction Box
- IP66/IP67 Rated
- Vandal Resistant with IK10 Ratings
- G3/4 Conduit Interfaces
- Aluminum Alloy Die-Cast Casing
- White Powder Coat RAL 9003
- Dimensions 134.3 (D) x 56.5 (H) mm
- Weight 395.6 gms

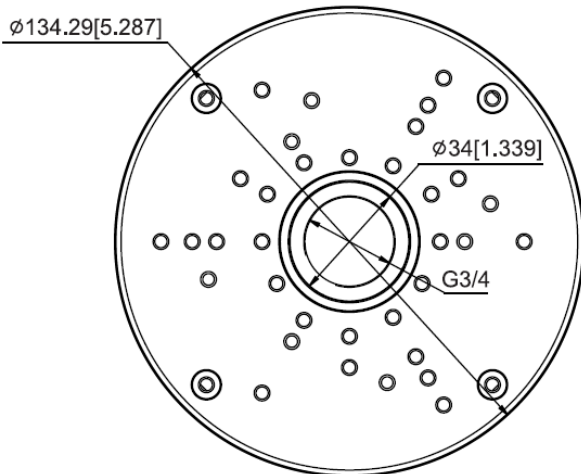

ORDERING INFORMATION	
PART NUMBER	DESCRIPTION
IJBW-134	Infinique Camera Junction Box, Wall Mount, 134.3 (D) x 56.5 (H) mm

infinique Infinique, a Canadian company is a manufacturer of high performing end-to-end solutions in copper, fiber and video surveillance systems. For more information visit our website at www.infinique.com or email us at sales@infinique.com.